



INTEGRATED ANALYSIS OF OFFSHORE STRUCTURES SUBJECTED TO FIRE

E Eberg, SINTEF
J Amdahl, The Norwegian Institute of Technology
T Holmås, SINTEF
B Hekkelstrand, SINTEF

1. INTRODUCTION

Traditionally, fire design is carried out on individual structural elements. The requirements have typically been formulated such that the temperature of the member should not, with or without passive/active protection means, exceed a critical temperature within a specific time depending upon its assumed importance. The basis for the evaluation has been results obtained in standard furnace tests.

In many cases, this is unsatisfactory:

- The time-temperature relationships used in standard furnace tests are not representative for the development of all different real fires.
- For practical reasons, only single components or a few members can be tested simultaneously in a furnace. This yields significant uncertainties with respect to modelling of boundary conditions.
- The use of standard furnace tests has led to the concept of a critical temperature of 500°C for steel structures. This is often conservative, especially for structures where significant redistribution capability exists, i.e. the forces in a failing member can be transferred to intact members in the adjacent structure.

The complexity of the fire engineering problem has up to now precluded the use of numerical tools for large scale analysis. However, recent progress in computational techniques for analysis of transient temperature states and nonlinear structural response now renders advanced calculations feasible. This is also reflected in several regulations. The codes issued by the Norwegian Petroleum Directorate /1/ specify fires as an accidental event which is to be designed for in the limit state of progressive collapse. In contrast to the traditional ultimate limit state criterion, this design criterion allows for local failures in the form of buckling, yielding, etc. provided that the structural integrity is not put in jeopardy.

The fire engineering design comprises at least three aspects:

- Combustion process
- Transient temperature states within the structure
- Mechanical response of the structure

Previously, these topics have been considered more or less individually, in particular the temperature - and mechanical response calculation of complex structures. In an ongoing research and development project, entitled "Integrated Analysis of Steel and Aluminium Structures Exposed to Fire" /2/, an efficient analysis system which integrates the topics of fire engineering design is developed being developed

2. INTEGRATED FIRE ANALYSIS

The analysis of fire exposure history is based upon the computer program KAMELEON FIRE which is a general purpose computer code for heat- and mass transfer calculations. Extensive mathematical models for combustion, radiation etc are included. Open and enclosed pool fires and jet fires are handled by the program.

The mechanical response analysis part is based upon the computer program USFOS /3/, which has been specifically developed for assessment of offshore structures subjected to a variety of accidental loads (ship-collision, dropped objects, fires, abnormal environmental forces etc.). Both jacket type structures as well as platform decks and module support frames can be analyzed with USFOS. Within the project a fire analysis module has been developed which is capable of calculating progressive collapse of large-scale structures for a given temperature field history.

The transient temperature analysis represents the interface between KAMELEON FIRE and USFOS. A special purpose program based upon the finite element technique is developed for the solution of this problem. The temperature analysis requires usually a considerably more refined geometrical modelling in order to model local heating, temperature gradients etc. Consequently an automatic remeshing capability is included. It transforms the space frame model used in the in the mechanical response analysis to a refined shell element model, saving the user for a large modelling task. The output from the temperature analysis describes the temperature versus time history at a large number of positions in the structure which may be inspected visually with the results presentation system XFOS.

The space frame modelling for the mechanical response analysis is performed according to the SESAM80 format which is widely used within the offshore industry. This facilitates the use of a standard preprocessor, e.g. the SESAM module PREFRAME. As many of the platforms built during the last decades already are modelled according to the SESAM80 format, reanalysis by use of the integrated system may also be performed very efficiently.

The SESAM format represents a very coarse FE model very close to the engineers physical interpretation of a structure in the sense that a beam or a column also represents an element in the FEM.

3. SIMULATION OF THE FIRE PROCESS

The basis for KAMELEON FIRE is the more general computer program KAMELEON developed for solving fluid flow, heat and mass transfer. The partial differential equations describing fluid flow, heat and mass transfer are the continuity equation, the momentum equations (Navier Stokes equations), the energy equation and conservation equations for components or species. These equations are sufficient to give an exact solution of simple fluid flow or heat transfer phenomena. More complex phenomena such as turbulent fluid flow or situations involving chemical reactions like fires have to be solved numerically.

To account for the effect of turbulence the well known two equation k- ϵ model of is used /4/. It requires the solution of the conservation equation for turbulent kinetic energy, k, and the conservation equation for the dissipation of the turbulent kinetic energy, ϵ . This model is relatively simple to use and is well tested.

The combustion model used in KAMELEON FIRE is the Eddy Dissipation Concept (EDC) developed by Magnussen /5/. It is a general concept for treating the interaction between the

turbulence and the chemistry in flames. The EDC identifies a reactor related to the fine structures of turbulence in the fluid. The reactor is treated as a homogeneous reactor exchanging mass and energy with the surrounding fluid, thus allowing a complete treatment of the chemistry.

This combustion model is chosen because it is easy to implement compared to other combustion models. It has proved to give very good results for a large number of different combustion phenomena ranging from diffusion to premixed flames.

In the simulation of fires a model for the soot formation and combustion is required. A model proposed by Magnussen et. al. /6/ is implemented. It is assumed that the soot production starts with the formation of nuclei which grow to soot particles. The soot combustion is calculated by the EDC concept.

To calculate the radiative heat transfer the Discrete Transfer Model by Shah and Lockwood /7/ is used. A discrete number of rays are originating from each point of the calculation domain. Each ray represents a part of the solid angle of the hemisphere around the boundary point. The sum of the solid angles must cover the total hemisphere (2π). Each ray is traced through the calculation domain and absorption and emission along the ray is calculated based on the local temperature and absorption coefficient of the local point or control volume the ray passes through. The source term of the enthalpy or energy equation in a control volume, is calculated based on all the rays that pass through. The radiant heat flux to each boundary point is determined from the intensity of all the rays originating from that point.

The numerical solution of the coupled set of PDE's is based on a finite volume technique. The solution algorithm is fully three dimensional and may be transient or stationary.

KAMELEON FIRE is equipped with a preprocessor which is an efficient tool for the user to define the fire scenario. The necessary input is the geometry (open/enclosed/obstacles), fuel characteristics (gas or liquid hydrocarbon), the state of the surroundings (ambient temperature/wind or ventilation conditions), fuel source (gas leakage/pool size) and wall characteristics for enclosed fires.

The most important results from KAMELEON FIRE are in this context the temperatures and radiant fluxes to obstacles and solid walls. Since the amount of data generated is large, inspection of the results is performed by a graphical post processor.

4. HEAT TRANSFER SIMULATION

The heat transfer simulation connects the fire simulation (KAMELEON FIRE) with the mechanical response analysis (USFOS). The gas temperature and radiation at each time step are given in a grid which envelops the entire structure as shown in Figure 1. From this the actual heat loads are determined and the temperature in each structural member is calculated. The mean temperature and gradients over the cross-section are stored and subsequently retrieved by USFOS.

The heat transfer simulations are carried out as follows:

- 1: A new FEM model is created based on the space frame model used by USFOS. It consists mainly of 4 node quadrilateral elements. The transfer from beam element to surface elements is illustrated in Figure 2 for an I/H - and tubular profile, respectively. Special elements are automatically introduced in tubular joints to connect the different braces. All hollow members contain an internal member element so that the effect of internal material (gas, water, ...) can be simulated.

2: Heat conduction, heat accumulation and exchange of radiation are calculated on the basis of the refined FEM model. The transient behaviour is based on the following equation:

$$KT + C\dot{T} = Q \quad (1)$$

where K is the conductivity matrix of the structure, C is the heat capacity matrix, T and \dot{T} are the vector of nodal point temperatures and the corresponding rates, respectively, and Q is the heat load vector.

The equation is solved in the time domain using a standard integration procedure.

3: The temperatures in each structural member are transferred to the space frame model.

Various types of insulation may be included in the heat transfer model. To avoid excessive CPU consumption a simplified numerical procedure has been chosen instead of resorting to conventional higher order volume elements for modelling of insulation. Further work will demonstrate the applicability of this algorithm.

5. MECHANICAL RESPONSE ANALYSIS

The fundamental principles behind USFOS are shown in Figure 3. The basic idea is to use one finite element per structural element which allows the use of the FE mesh from linear analysis. The elastic stiffness matrices contains the influence of large lateral deformations (in the form of the so-called Livesly's stability functions).

Nonlinear material behaviour is taken into account by means of a concentrated plasticity model (plastic hinges). The yield criterion is expressed in terms of the stress resultants (axial force, shear force, torsion- and bending moment) normalized versus the plastic capacities.

$$F(N, Q_y, Q_z, M_x, M_y, M_z, \sigma_y) = 0 \quad (2)$$

Normally, this is equated for a cross-section in the fully plastic state. E.g. for a tubular cross-section subjected to simultaneous axial force and bending moment simple integration yields

$$F = \frac{\sqrt{M_x^2 + M_y^2}}{zM_p} - \cos \frac{\pi}{2} \frac{N}{zN_p} = 0 \quad (3)$$

where

$M_p = \sigma_y W_p$ plastic bending moment

$N_p = \sigma_y A$ plastic axial force

The size of the failure surface is given by the factor z . To allow for gradual plastification of a cross-section the so-called bounding surface theory in the force space is used. Two failure surfaces are utilized. One surface denoted the yielding surface ($z=1/\text{shape factor}$) defines initial yielding of the extreme fiber, while the bounding surface ($z=1$) defines the state of full plastification. Between these two states a smooth transition is used to model the real plastification process.

The plastic hinge concept allows separation of elastic and plastic displacement for a cross-section having attained, the fully plastic state. The plastic displacements are confined to hinges of zero length while the beam remains elastic between hinges.

In this way no numerical integration is required in order to obtain incremental and total equilibrium equations.

Several special features are implemented. Elastic and plastic flexibility of joints may be taken into account; the latter in the form of interaction functions for joint capacity as e.g specified in the API code. Interaction between local denting/buckling and beam bending is incorporated; the dent reduces the plastic capacities while the axial force influences the resistance to local denting. The strains at member ends and at midspan are surveyed. Once the critical level is exceeded, which is determined on the basis of 3rd level CTOD approach, rupture is assumed to take place. The member and its associated forces are removed from the finite element model.

In addition to the 3-D beam, elastic and nonlinear spring elements as well as a 4 node membrane element for modelling of in plane behaviour of cellular structures are available. The cross-section type may be tubular, box, I-section or a user defined general section.

The thermal load effects considered are

- thermal expansion
- reduction of E-modules
- reduction of yield stress

while implementation of creep is forthcoming. (Normally a certain amount of creep is presupposed in the E-modulus and the yield stress relationships prescribed by the various codes). The temperature is assumed constant in the axial direction, but can have a bi-linear distribution over the cross-section. The temperature at the beam's axis is taken as the reference point for determining the current values of yield stress and E-modulus. For simplicity they are not assumed to vary over the cross-section.

The major effect of temperature loading on an elastic element is to produce consistent nodal forces, which contain the following contributions

- consistent nodal forces due to axial expansion and temperature gradient increment over the cross section
- consistent nodal forces due to an increment of the elastic modulus.

The effect of yield stress degradation is considered in the space of stress resultants. With increasing temperature the yield surface contracts and yielding is initiated at an earlier stage as compared with normal temperature. After a hinge has been inserted, the yield surface continues to contract at increasing temperatures. This causes a contribution to the consistent nodal forces which constrain the force state to remain on the contracting yield surface.

This is illustrated in Figure 4 which shows simulated thermal induced buckling of an I-beam with axially restrained ends. The beam has an initial axial compressive load of 0.5 MN and an initial lateral deflection of 10 mm. It is modelled by means of 2 finite elements. The heating is applied at a rate of 10^0 C/min.

Figure 4a shows the lateral displacement as a function of the time. Point I indicates the position of buckling whereby the lateral deflection increases significantly. The agreement with the results of the computer program CAMFEM /8/ is good. In the latter calculations 8 beam elements and 20 layers over the cross-section were used. Figure 4b shows the axial force-bending moment history at midsection. The reduction of load-bearing capacity caused by contraction of the yield surface is demonstrated.

Depending on the heating conditions, structural geometry and isolation complex and nonuniform temperature fields may occur over the cross-section and along the beam.

Because the response calculation in USFOS is based upon a bi-linear temperature distribution, it is necessary to transform the actual temperature field into an equivalent bi-linear distribution. This is carried out in such a way that the equivalent temperature field preserves elastic strain energy.

To check the performance of the simplified formulation a comparative study on thermal column buckling has been made with the general purpose FEM program ABAQUS. A pinned tubular column is initially loaded in compression up to 60 % of the yield force. The column is then exposed to an increasing temperature field until thermal buckling occurs. In addition to uniform heating various cases of temperature gradients over the cross section are examined, maintaining uniform temperature state in the length direction. The USFOS model consists of one single beam element, while 10 beam elements are used in the ABAQUS analysis.

For the cases with uniform heating and a linear temperature distribution over the cross section, the behaviour predicted by USFOS is seen to agree well with the results obtained by ABAQUS. Figure 5 depicts the midspan lateral deflection versus temperature.

For the extreme nonlinear temperature case, a simplified equivalent linear field as shown in Figure 5 is used by USFOS. The response predicted by USFOS corresponds quite well with ABAQUS in the elastic range. However, as yielding becomes predominant USFOS overpredicts the capacity slightly and the collapse takes place more abruptly. This is due to the underlying simplification in the plastic hinge model; the yield stress degradation is constant over the cross-section and is based on the temperature on the neutral axis. Improved accuracy may be obtained by using "exact" plastic capacities found by numerical integration of reduced yield stresses over the cross-section.

6. ILLUSTRATIVE EXAMPLE

Figure 6 shows an 8-legged platform exposed to a hypothetical fire. It is assumed that fire occurs at the sea surface around the four centre legs with a slightly asymmetric exposure to the structure. Full lines indicate members heated to a temperature of 100°C and dotted lines those heated to 75 deg C, used as reference loads in the collapse analysis. This corresponds to 25% faster heating of the right centre legs compared to the left ones.

Figure 7 shows the deformed platform at the point of collapse. Failure is precipitated by loss of bending moment capacity of the deck truss-work girder and occurs at a temperature of 600°C. First yielding takes place already at 120°C and the lower center brace of the deck girder buckles at 170°C. Buckling is mainly the result of constrained thermal expansion caused by the upper part of the deck which is not exposed to the fire. It does not influence the load-carrying capacity considerably because the lateral deformation is governed by the thermal expansion. However, once the temperature level exceeds 500°C the capacity of the members starts to be reduced significantly due to yield strength degradation.

This is shown in Figure 8a where the axial force - bending moment interaction at mid section for the lower centre brace is depicted. It is demonstrated how contraction of the yield surface governs the capacity of the cross-section.

Figure 8b demonstrates the redistribution of forces within the four legs of the face. Due to thermal expansion the two center legs are subjected to compression whereas the external legs act in tension. This process continues until the yield strength degrades so much that the center legs start to yield at about 500°C. This triggers the collapse.

7. CONCLUSIONS

The integrated program system being developed now renders collapse analysis of actual offshore platforms subjected to complex fire scenarios feasible.

The program for analysis of mechanical response has shown satisfactory agreement in comparison with available test results on beam-columns and frames and with predictions by alternative finite element programs. In particular, the simplified representation of complex cross-sectional temperature profiles has proved to be acceptable.

The mechanical response to temperature loads can be complex. In a redundant structure the temperature at ultimate collapse can be significantly higher than the temperature at first element failure.

ACKNOWLEDGEMENT

The present paper is the result of work carried out in the project "Integrated Analysis of Steel and Aluminium Structures Exposed to Fire", supported by NTNF, Elf Aquitaine, Phillips Petroleum Company, Saga Petroleum and Hydro Aluminium Structures

REFERENCES

- /1/ "Regulations for structural design of load-bearing structures intended for exploitation of petroleum resources". The Norwegian Petroleum Directorate, 1984.
- /2/ H. Landrø, J. Amdahl and B.F. Magnussen: Integrated analysis of steel and aluminium structures exposed to fire, Report No. 71-90005, SINTEF, Trondheim, Norway, 1990.
- /3/ USFOS - A computer program for progressive collapse analysis of steel offshore structures. - Joint Industry Project, Report No: PF-71-87019, SINTEF, Trondheim, Norway, 1987.
- /4/ Launder, B.E. and Spalding D.B.: Computer Methods in Applied Mechanics and Engineering, No. 3, pp 269-289, 1972
- /5/ Magnussen, B.F.: "Modelling of NO_x and Soot Formation by the Eddy Dissipation Concept". Presented at the International Flame Research Foundation 1st Topic Oriented Meeting, Amsterdam, 1989
- /6/ Magnussen, B.F., Hjertager, B.H., Olsen, J.G. and Bhadrin, D.: The 17th Symposium on Combustion, The Combustion Institute, p. 1383, 1978
- /7/ Shah, N.G.: " The Computation of Radiation Heat Transfer", Ph.D. Thesis, University of London, Faculty of Engineering, 1979
- /8/ Peterson, A.: "Finite Element Analysis of Structures at High Temperatures", Rep. TVSM-1001, Div. of Structural Mechanics, Lund Institute of Technology, Lund, Sweden, 1984.

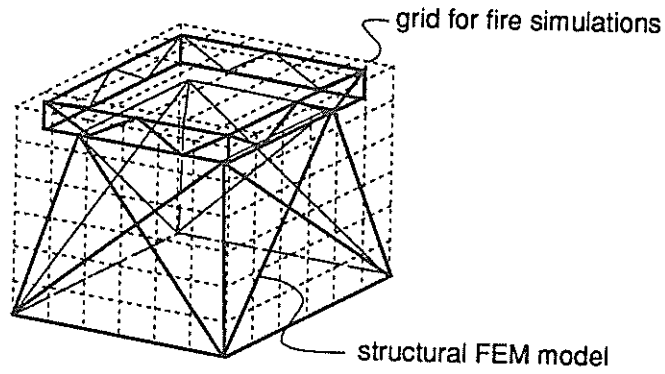

Figure 1. Grid for fire analysis

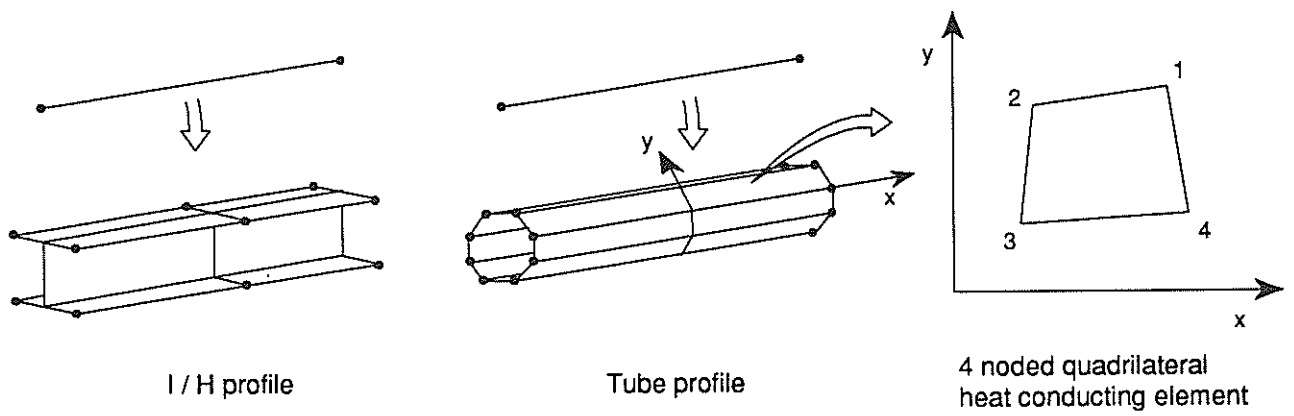

Figure 2. Remeshing of beam elements to surface elements for temperature analysis.

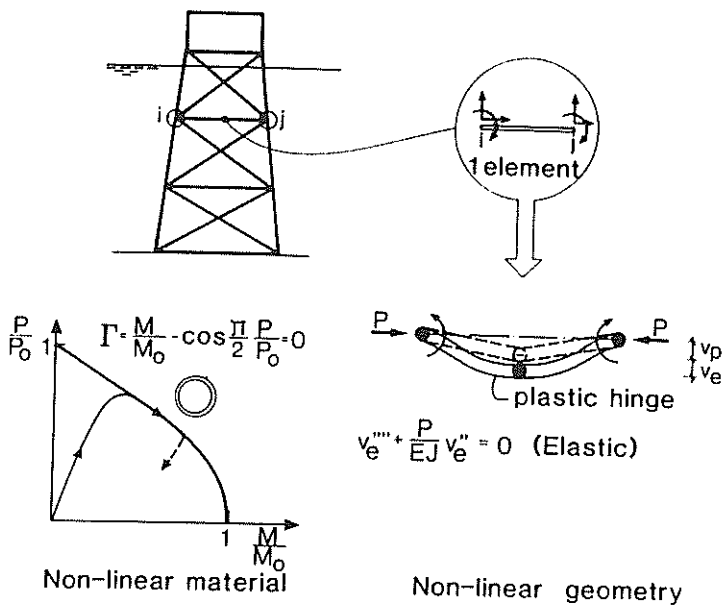
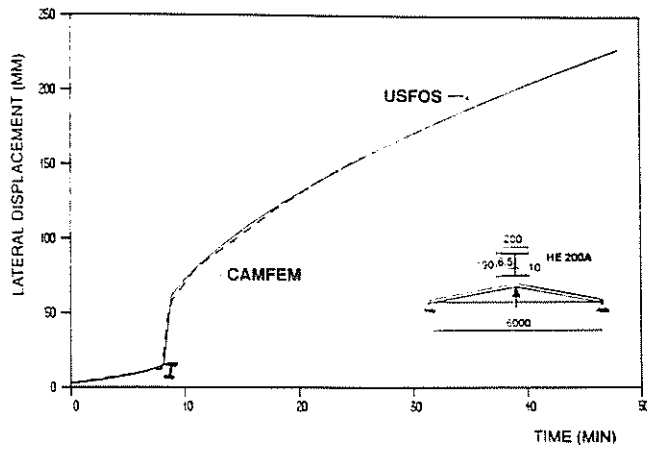
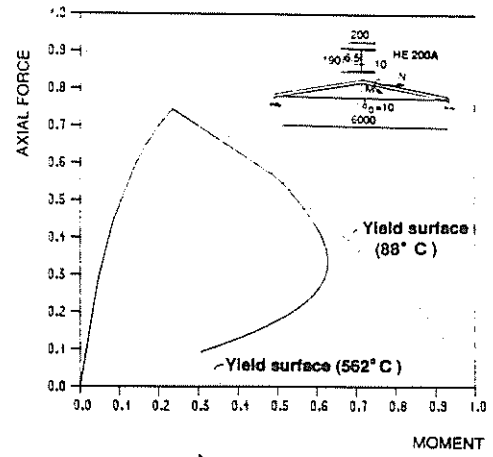

Figure 3. USFOS - basic concepts



a) Lateral displacement versus time
Figure 4. Thermal induced buckling



b) Axial force - bending moment interaction

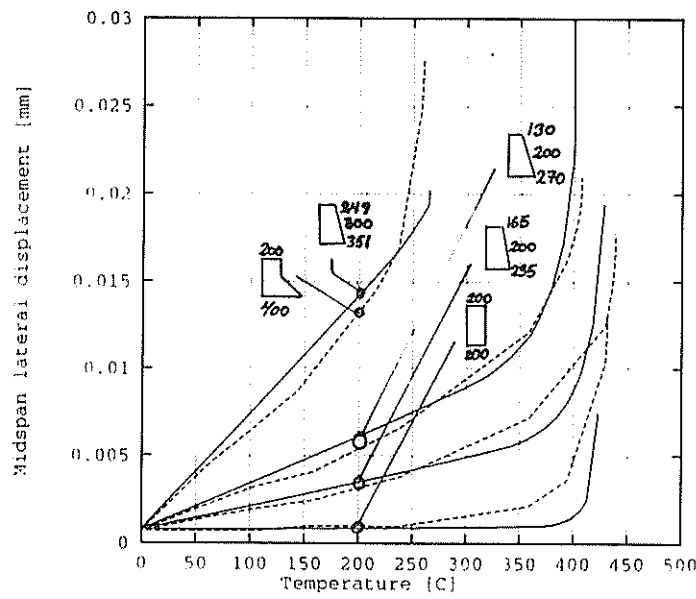

Figure 5. Thermal buckling of axially loaded column. (X-axis refers to centre line temperature)
— USFOS - - - ABAQUS

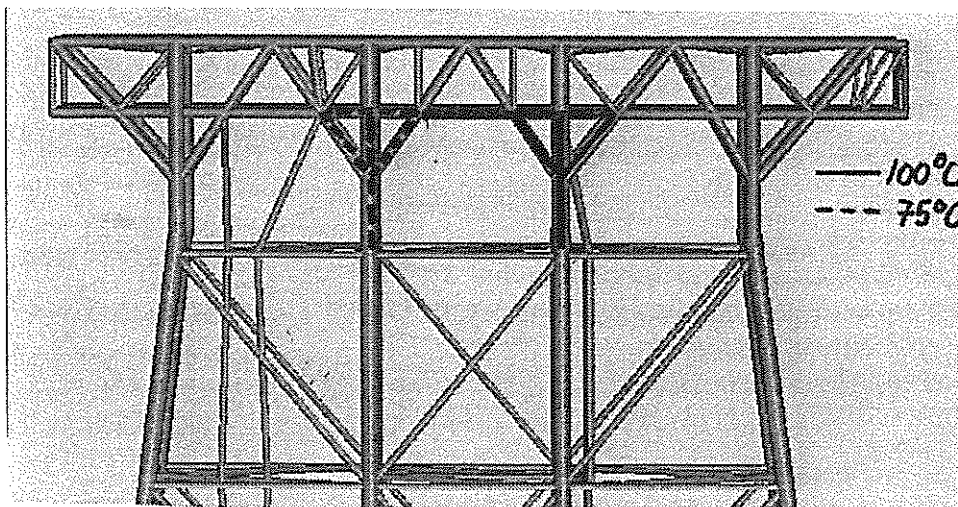

Figure 6. Assumed temperature field for the platform.

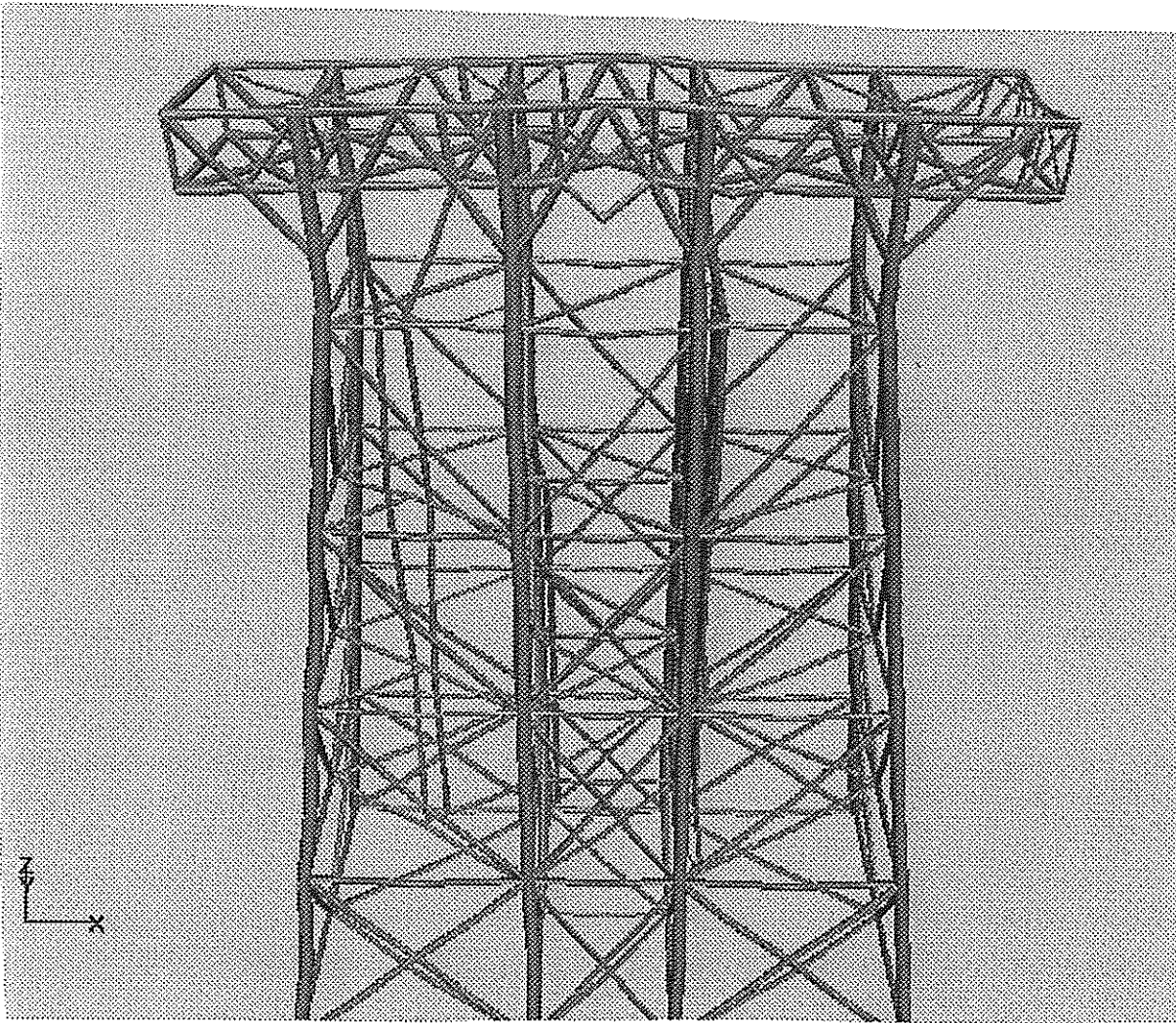
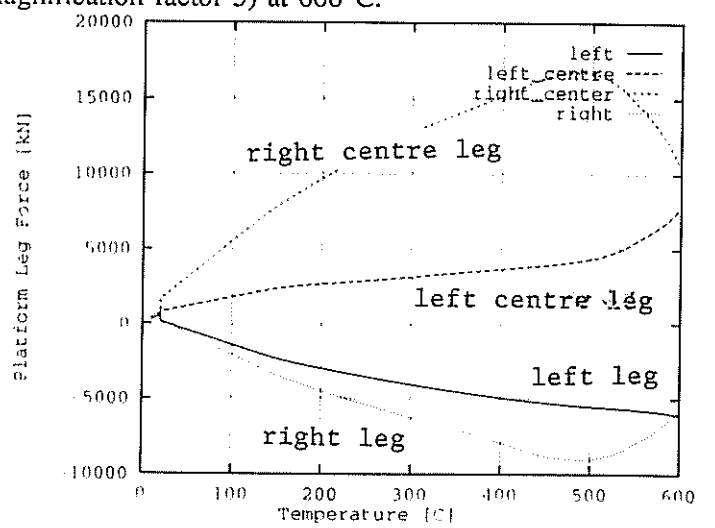
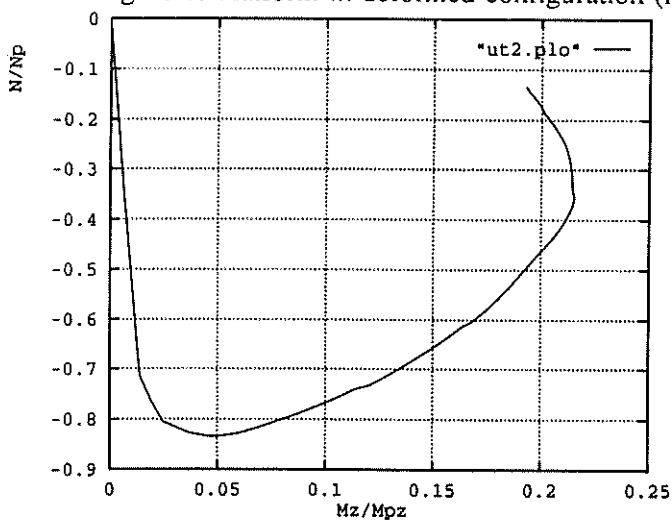

Figure 7. Platform in deformed configuration (magnification factor 5) at 600°C.



a) Axial force-bending moment interaction for lower centre brace. b) Axial force history in legs
Figure 8. Temperature induced response in members